



-power in control



DATA SHEET



Genset Controller, GC-1F

- Engine control
- Generator monitoring
- Generator protection (ANSI)
- Mains monitoring
- Mains protection (ANSI)
- Engine monitoring
- Display panel



DEIF A/S · Frisenborgvej 33 · DK-7800 Skive
Tel.: +45 9614 9614 · Fax: +45 9614 9615
info@deif.com · www.deif.com

Document no.: 4921240406B
SW version:

1. Application information

1.1. General information.....	3
1.1.1. Genset controller description.....	3
1.1.2. Setup of the controller	3
1.1.3. Language	3
1.1.4. Translation	3
1.1.5. Options	3

2. Terminals

2.1. Terminal overview.....	4
2.1.1. Description.....	4

3. Optional functionality

3.1. Available options and accessories.....	7
3.1.1. Available options	7
3.1.2. Available accessories.....	8
3.2. Display layouts.....	9
3.2.1. AMF layout example.....	9
3.2.2. Option Y10 source to source display layout.....	9
3.3. Folio examples.....	10
3.3.1. Y2 and G6 folio	10

4. Wiring

4.1. Engine interface.....	11
4.1.1. Connection example	11
4.2. AC interface.....	13
4.2.1. Connection of the 3-phase voltage and current	13
4.2.2. AMF option B3 wiring	14

5. Technical information

5.1. Specifications and dimensions.....	16
5.1.1. Technical specifications	16
5.1.2. Unit dimensions in mm (inches)	19

6. Ordering information

6.1. Order specifications and disclaimer.....	20
6.1.1. Order specifications.....	20
6.1.2. Disclaimer.....	20

1. Application information

1.1 General information

1.1.1 Genset controller description

The Genset Controller GC-1F/2 is a microprocessor-based control unit containing all necessary functions for protection and control of a diesel engine. Furthermore, it contains a three-phase AC voltage measuring circuit. The unit is equipped with an LCD display presenting all values and alarms. GC-1F is a compact all-in-one unit designed for the following applications:

1. Automatic engine start/stop
2. Engine protection
3. Breaker control
4. Generator protection
5. Automatic Mains Failure
6. Automatic Transfer Switch control*

GC-1F automatically carries out a cyclical self test. If any errors are found, the status relay output will deactivate (normally closed). In order to save battery power, the display can be set to switch off automatically after a given period of time. The display will turn on again if events or alarms take place, or if one of the push-buttons is activated.

1.1.2 Setup of the controller

The parameter settings and M-Logic programming can easily be done via a PC Windows®-based utility software (USW). The USW is password-protected - for further information please read the help file in the USW editor.

To interface the GC-1F from the PC, there are two possibilities. One is option J5, which is RS232 with an interface box between PC and GC-1F. The other option is J9, which is USB to TTL interface between PC and GC-1F. Both cable options J5 and J9 are galvanically isolated and will protect your PC if it is connected during genset operation.

The PC utility software offers additional features such as monitoring of all relevant information during commissioning, saving and downloading of settings and downloading of software updates. Furthermore, the most frequently used settings can be accessed via the display push-buttons, which are password-protected.

1.1.3 Language

The master language is English and, furthermore, there are three selectable languages. These are listed in the order specifications.

1.1.4 Translation

This function makes it possible to translate all texts used in the unit.

1.1.5 Options

The options selected by the customer will be integrated in the standard GC-1F, securing the same user interface regardless if the application needs are basic or a more complex genset controller.

2. Terminals

2.1 Terminal overview

2.1.1 Description

Terminal	Technical data	Description
1	Power supply +	Aux. supply
2	Power supply –	GND
3-4	Status out/configurable. Contact ratings 1 A 24V DC/V AC Resistive	General status output for marine approvals/ only configurable in hw 1.05 and sw 2x.x.
9	Common	Common for term. 10...15
10	Digital input	Start enable/configurable
11	Digital input	Remote start/stop/configurable
12	Digital input	Charge alternator D+ (running)/configurable
13	Digital input	Configurable
14	Digital input	Coolant temperature/configurable
15	Digital input	Oil pressure/configurable
19	Common	Common for emergency stop term. 20
20	Emergency stop and common for 21...23	Common for relays 1, 2 and 3 and input for emergency stop *
21	Relay output 21. Contact ratings 2 A 30V DC/V AC (UL/cUL Listed: 1 A Resistive)	Start prepare/configurable. Function NO
22	Relay output 22. Contact ratings 2 A 30V DC/V AC (UL/cUL Listed: 1 A Resistive)	Starter (crank)/configurable. Function NO
23	Relay output 23. Contact ratings 2 A 30V DC/V AC (UL/cUL Listed: 1 A Resistive)	Run coil/configurable. Function NO
24-25	Relay output 24. Contact ratings 8 A 30V DC/V AC (UL/cUL Listed: 6 A Resistive)	Horn/configurable. Function NO
26-27	Relay output 26. Contact ratings 8 A 30V DC/V AC (UL/cUL Listed: 6 A Resistive)	Alarm/configurable. Function NO
Multi-functional inputs		
5	Common	Common for term. 6...8
6	VDO1/0(4)...20 mA/binary input	Fuel level/configurable
7	VDO2/0(4)...20 mA/binary input	Oil pressure/configurable
8	VDO3/0(4)...20 mA/binary input	Water temp./configurable
Tacho RPM input		

Terminal	Technical data	Description
16	RPM input (MPU)	Magnetic pick-up tachometer generator
17	RPM-GND	Common for RPM input
18	RPM input (W/L)	Magnetic pick-up. PNP, NPN or charge alternator W terminal
3-phase generator voltage input		
33	Gen. voltage L1	Generator voltage and frequency
34	Gen. neutral	
35	Not used, must not be connected	
36	Gen. voltage L2	
37	Not used, must not be connected	
38	Gen. voltage L3	
3-phase generator current input		
39	Gen. current L1, s1	Generator current
40	Gen. current L1, s2	
41	Gen. current L2, s1	
42	Gen. current L2, s2	
43	Gen. current L3, s1	
44	Gen. current L3, s2	
3-phase mains voltage inputs		
28	Mains voltage L1	
29	Mains voltage neutral	
30	Mains voltage L2	
31	Not used, must not be connected	
32	Mains voltage L3	
Breaker relays		
45	Relay R45. Contact ratings 2 A 30V DC/250V AC (UL/cUL Listed: Contact ratings 2 A 30V DC/30V AC)	Generator circuit breaker/configurable, function NO (normally open)
46	Relay R45	
Optional relay for closing mains breaker (option B3)		
47	Relay R47. Contact ratings 2 A 30V DC/250V AC (UL/cUL Listed: Contract ratings 2 A 30V DC/30V AC)	Mains circuit breaker/configurable, function NC (normally closed)
48	Relay R47	
Optional relay NO contact (option M19)		

Terminal	Technical data	Description
47	Relay R47. Contact ratings 2 A 30V DC/250V AC (UL/cUL Listed: Contact ratings 2 A 30V DC/30V AC)	Mains circuit breaker/configurable, function NO (normally open)
48	Relay R47	
Optional Modbus RS485 interface (option H2)		
49	B (-)	Modbus RS485 RTU or ASCII
50	GND	
51	A (+)	
Optional CANbus #1 engine interface (option H5)		
53	CAN-H	CAN J1939 engine communication
54	CAN-GND	
55	CAN-L	
Optional CANbus #2 AOP-2 interface (option X4)		
57	CAN-H	CAN communication line to AOP-2
58	CAN-GND	
59	CAN-L	
Optional CANbus #2 ext. I/O interface (option H8)		
57	CAN-H	CAN communication line to external I/O
58	CAN-GND	
59	CAN-L	

* Only possible with HW 1.05 and SW 2.2x.x.

3. Optional functionality

3.1 Available options and accessories

3.1.1 Available options

Option	Description	Type	Note
B	Generator protection		
B3	Automatic Mains Failure and ATS control - Generator and mains breaker control - Change-over (no synchronisation)	Software option	ATS mode is only available in HW 1.05 and SW 2.2x.x Option B3 must also be set
G	Breaker		
G6	Front layout with generator breaker	Hardware option	
H	Communication		
H2	Modbus RS485 RTU or ASCII	Software option	
H5	CANbus J1939 CANbus #1 comm. - Detroit Diesel - John Deere - Deutz - Volvo Penta EMS - Volvo Penta EMS 2 - Scania EMS - Scania EMS 2 - MTU MDEC 302 - MTU MDEC 303 - MTU ADEC - Cummins - Iveco - Perkins - Caterpillar	Software option	
H8	External I/O CANbus #2 comm.	Software option	See supported modules in option H8 documentation
L	Heatfoil for display	Hardware option	
L2	Display will operate down to -40°C	Hardware option	Only HW 1.05 and ASW 2.0x.x
M			
M19	Mains circuit breaker/configurable, contact function NO (normally open)	Hardware option	Only HW 1.05 and ASW 2.2x.x
Y	Folio		

Option	Description	Type	Note
Y2	Engine folio without generator symbol, generator and mains breaker	Hardware option	
Y10	Source – source folio with breaker symbols	Hardware option	Only HW 1.05 and ASW 2.2x.x

3.1.2 Available accessories

Accessories	Description	Item no.	Note
Operator panels			
Additional Operator Panel, AOP-2 (X4)	16 configurable LEDs, 8 configurable buttons and 1 status relay. CANbus comm.	2912890050	Five AOP-2 units can be used with each unit
Gasket for IP65	Gasket for IP65	1129150061	
J	Cables		
J5	PI-1 converter box kit (for PC connection)	2032410047	
J9	USB to TTL galvanic isolation (for PC connection)	1034000011	
K	Documentation		
K1	Installation Instructions and Reference Handbook (hard copy)	4189340472	
K2	CD-ROM with complete documentation	2304230002	

3.2 Display layouts

3.2.1 AMF layout example

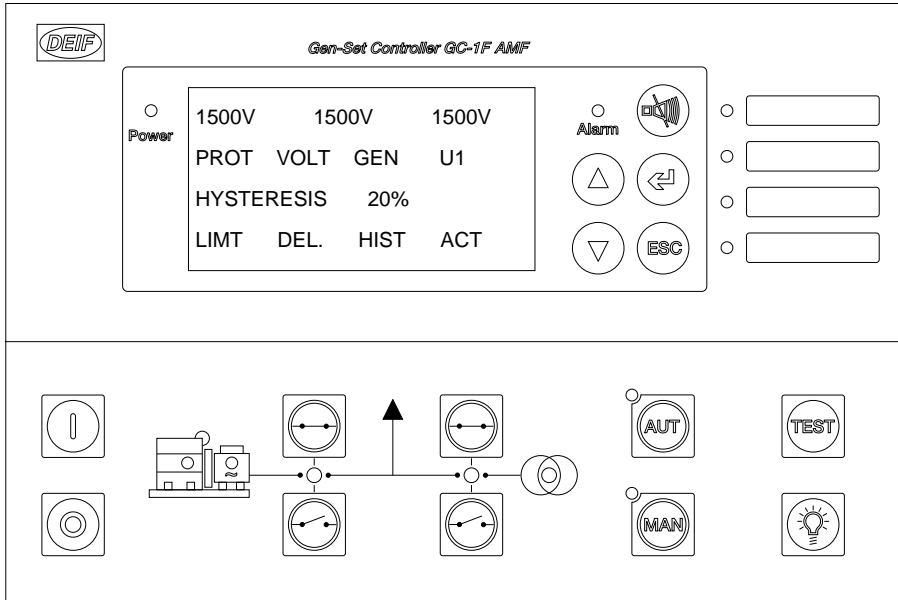

3.2.2 Option Y10 source to source display layout

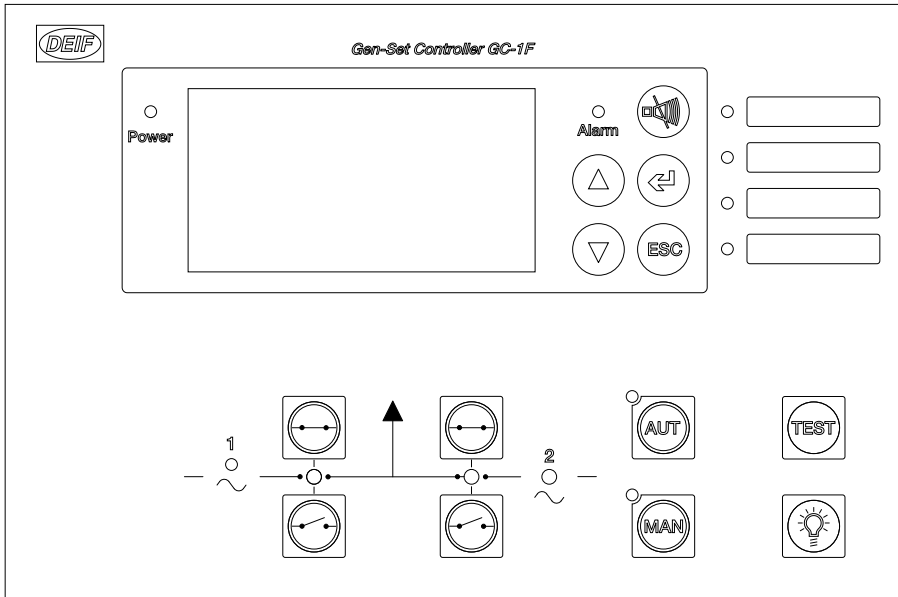

3.3 Folio examples

3.3.1 Y2 and G6 folio

Y2 folio:

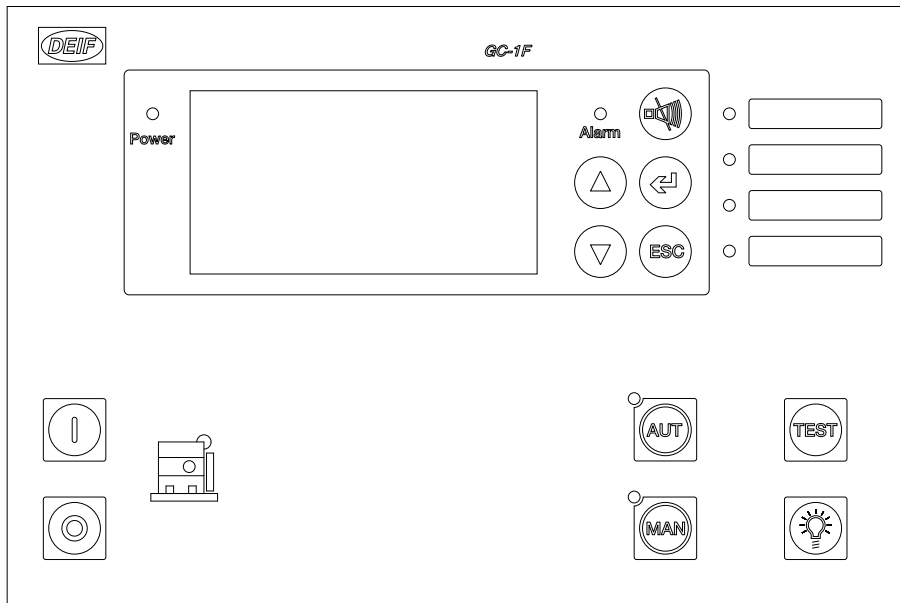

G6 folio:

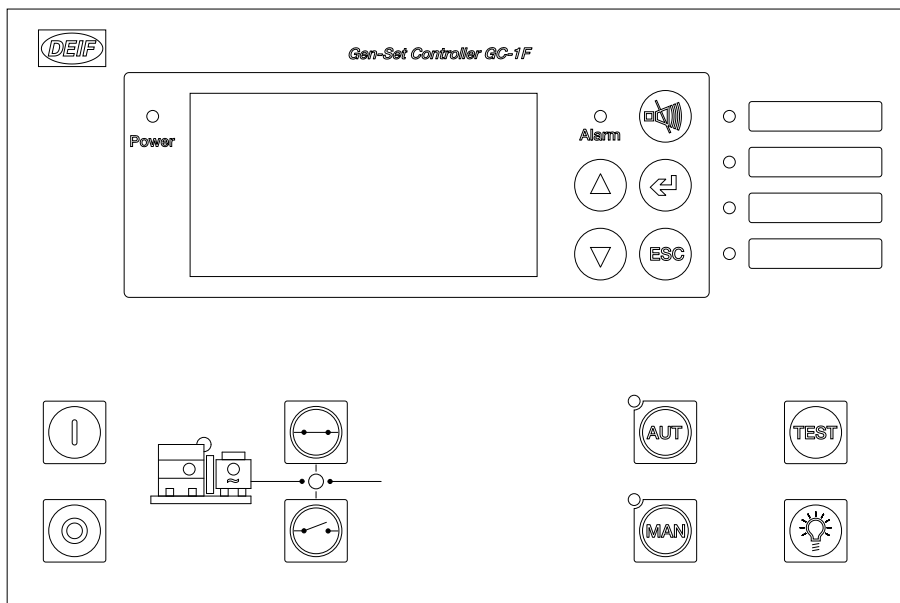

4. Wiring

4.1 Engine interface

4.1.1 Connection example

 F: fuse: min. 2 A slow-blow.

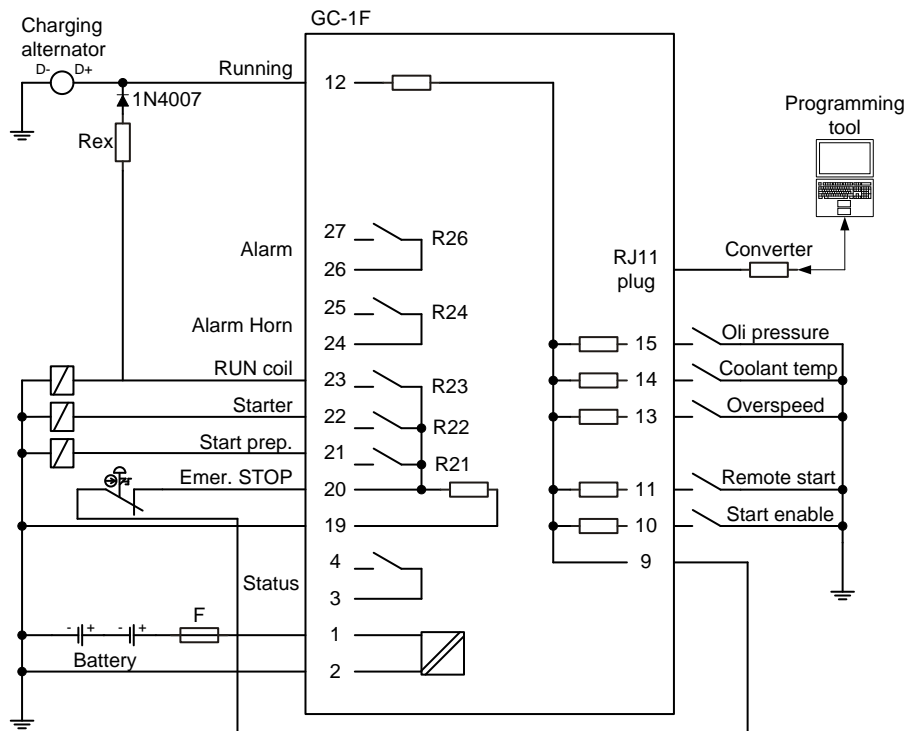

Term. 12 can be used as alarm input if not used for charger generator terminal D+

Rex: 12V systems : 47Ω 4W
 24V systems : 100Ω 6W

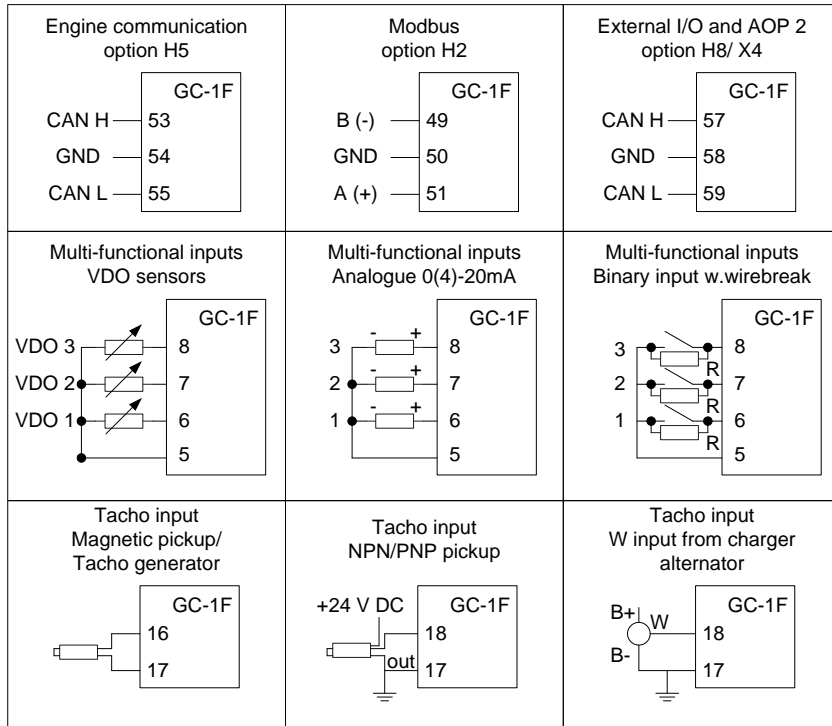

It is possible to combine VDO inputs with binary and 0(4)...20 mA inputs in a mix.

4.2 AC interface

4.2.1 Connection of the 3-phase voltage and current

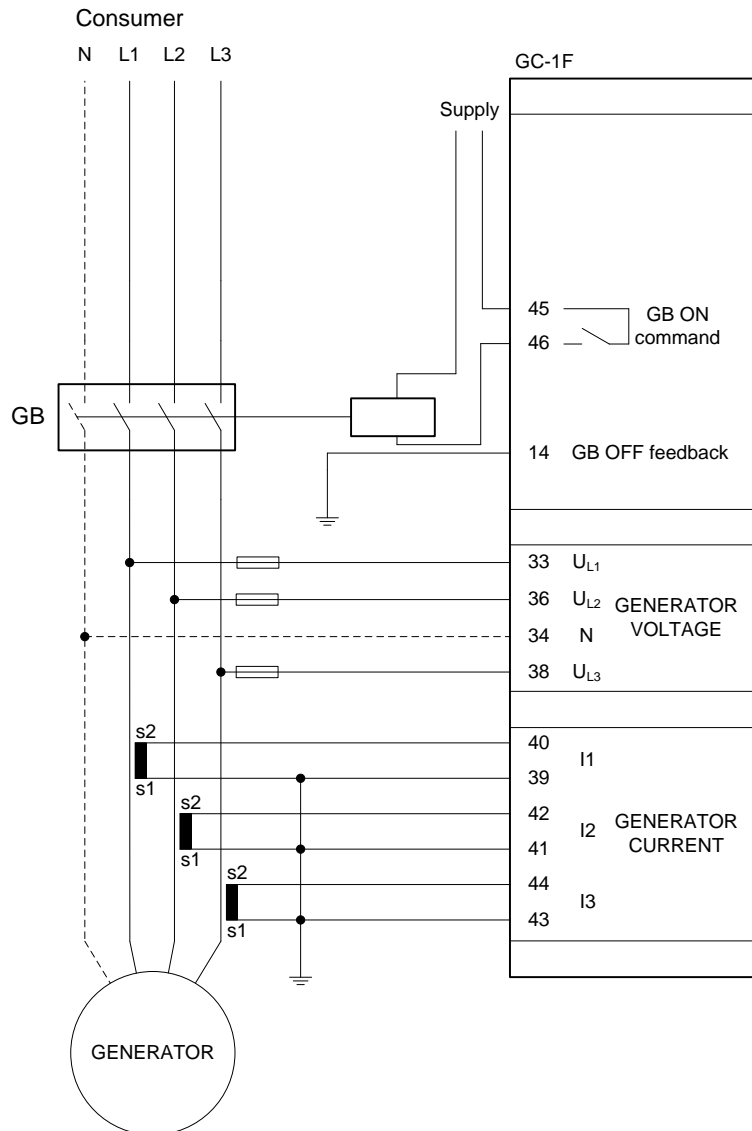

The AC current grounding can be made as required to s1 or s2.



GB: use a contactor. The ON output from the GC-1F is a constant signal. Remember to use free-wheel diodes across the contactor coils if DC voltage is used as supply for these.

Fuse for AC voltage: max. 2 A slow-blow.

4.2.2 AMF option B3 wiring

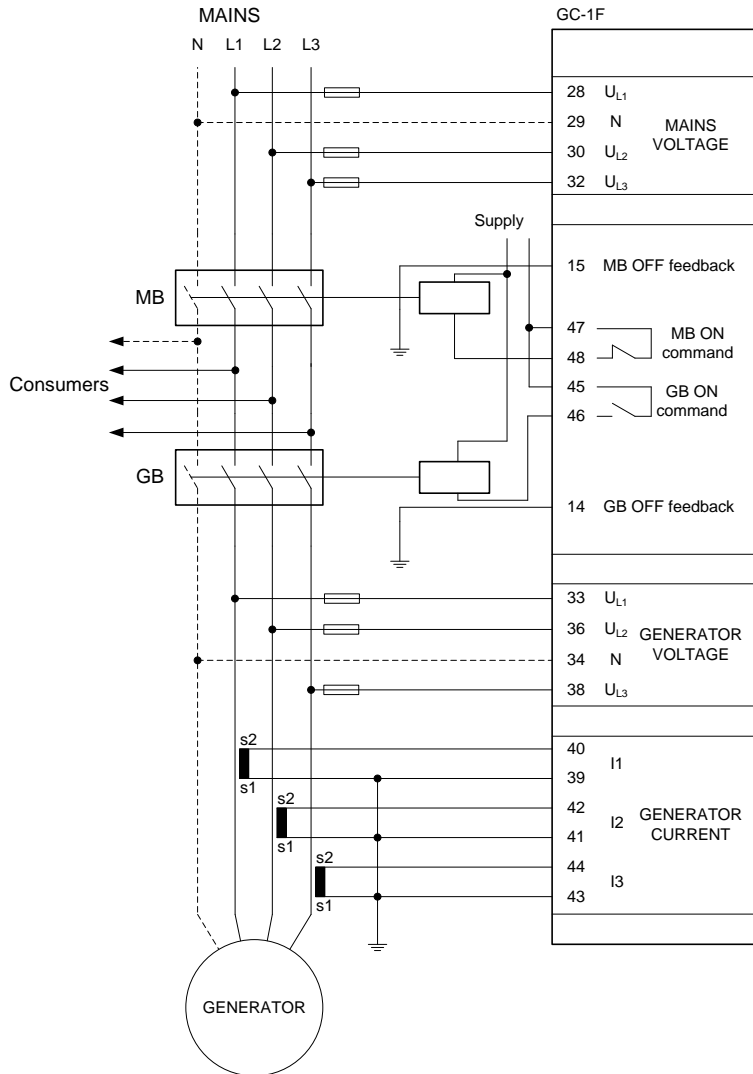

The AC current grounding can be made as required to s1 or s2.



GB and MB: use contactors. The ON outputs from the GC-1F AMF are constant signals. Remember to use free-wheel diodes across the contactor coils if DC voltage is used as supply for these.

Fuse for AC voltage: max. 2 A slow-blow.

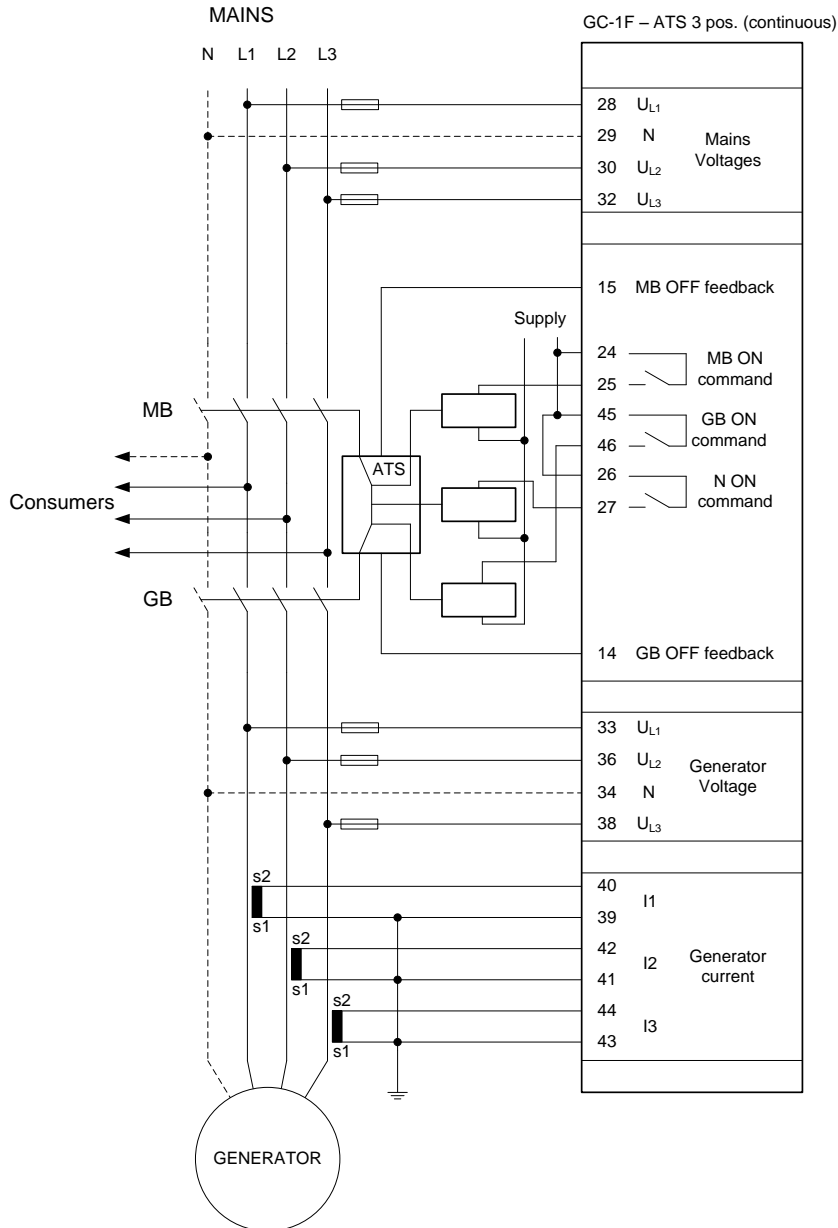

The GC-1F can operate ATS switches in Gen - Mains and Source - Source applications.



Relay outputs can be configured for pulse or continuous signals for 2 or 3 position ATS. Detailed information about different variants can be found in the option B3 manual.

Fuse for AC voltage: max. 2 A slow-blow.

5. Technical information

5.1 Specifications and dimensions

5.1.1 Technical specifications

Accuracy	Class 2.0 To EN 60688
Operating temperature	-20...70°C (-4...158°F) -40...70°C (-40...158°F) with option L2 (UL/cUL Listed: max. 50°C ambient)
Storage temperature	-40...70°C (-40...158°F)
Heatfoil (option L2)	Display will operate down to -40°C
Measuring input voltage	50...480V AC (+20%) phase-phase Short circuit protection: 3% of 350%*I _n (only available from HW 1.05 and 2.0x.x) (UL/cUL Listed: 50...300V AC) Load: 1.5 MΩ/phase
Frequency	30...70 Hz
Measuring input current	1 A or 5 A AC from current transformer Current overload: 4 x I _n continuously 20 x I _n , 10 sec. (max. 75 A) 80 x I _n , 1 sec. (max. 300 A) Consumption max.: 0.3 VA/phase (UL/cUL Listed: use listed or R/C (XODW2.8) current transformers)
Pick-up input voltage	2...70 V peak Frequency: 10-10000 Hz
Aux. supply	6-36V DC continuously Max. 8 W consumption Including L2 heatfoil, max. 16 W (UL/cUL Listed: 7.5...32.7V DC)
Passive binary input voltage	Bi-directional optocoupler 6...36V DC Impedance: 4.7 kΩ OFF: <2V DC
Dropout cranking	Able to survive 0 V for 50 ms at 12V DC aux. supply before dropout
VDO inputs	Resistor inputs, internal 3 V supply
Analogue input	From active transducer
Current	0(4)...20 mA
Impedance	50 Ω
Active binary input voltage	Dry contact inputs (see note) 3V DC supply, with cable supervision

Relay outputs	Impedance: 240 Ω ~ 16 mA Relays 21-23: 30V AC/DC 2 A (UL/cUL Listed: 30V DC 1 A Resistive) Relays 45, 47: 250V AC/30V DC 2 A (UL/cUL Listed: 30V DC 2 A Resistive) Relays 24, 26: 30V AC/DC 8 A (UL/cUL Listed: 30V DC 6 A Resistive) Status relay/config.: 24V DC 1 A Resistive
Response times (delay set to min.)	Generator: Reverse power: <400 ms Power overload: <400 ms Overcurrent: <400 ms Over-/undervoltage: <400 ms Over-/underfrequency: <400 ms Fast overcurrent: <300 ms
Mounting	Panel-mounted (UL/cUL Listed: for use on a flat surface of a type 1 enclosure. Main disconnect must be provided by installer)
Size	160 x 220 mm (6.30" x 8.66")
Climate	97% RH to IEC 60068-2-30, test Db -20°C (-40°) to IEC 60068-2-1 +70°C to IEC 60068-2-2
Display	128 x 64 pixel backlight STN 3 line views can max. show a value of 9999
Safety	To EN 61010-1, UL508 and CSA22.2 no. 14-05 Installation category (overvoltage category) III, 300 V, pollution degree 2
Protection	Front: IP52/NEMA type 1 (IP65/NEMA type 1 with gasket, option L) Terminals: IP20/NEMA type 1 To IEC/EN 60529
EMC/CE	To EN 61000-6-1/2/3/4 IEC 60255-22-1/EN 61000-4-18 (PL3), IEC 60255-26
Material	All plastic materials are self-extinguishing according to UL94 (V1)
Plug connections	AC voltage/current inputs: 3.5 mm ² (13 AWG) multi-stranded Other: 1.5 mm ² (16 AWG) multi-stranded (UL/cUL Listed: wire size: AWG 30-12 Use 60/75°C copper conductors only)
Tightening torque, min.	AC voltage input: 0.5 Nm (5-7 lb-in) Other: 0.5 Nm (5-7 lb-in)
PC connection	RS232 converter box (option J5) or USB interface cable (option J9)
Weight	0.9 kg (1.9 lbs)
Installation	To be installed in accordance with the NEC (US) or the CEC (Canada)
Approval	CE & UL/cUL Listed UL/cUL Recognized to UL2200
Additional operator panel AOP-2	

Operating temperature	-20...70°C (-4...158°F) (UL/cUL Listed: max. 60°C ambient)
Storage temperature	-40...70°C (-40...158°F)
Aux. supply	18...36V DC by external DC/DC converter 12DCR24/5 supplied from controlled Class 2 source
Terminals	Tightening torque: 0.4 Nm (4 lb-in)
Wiring	Size AWG 30-12 Use 60/75°C copper conductors only
Mounting	Panel-mounted (UL/cUL Listed: for use on a flat surface of type 1 (IP54) enclosure. Main disconnect must be provided by installer)
Installation	(UL/cUL Listed: to be installed in accordance with the NEC (US) or the CEC (Canada))
Approval	CE & UL/cUL Listed UL/cUL Recognized to UL2200

5.1.2 Unit dimensions in mm (inches)

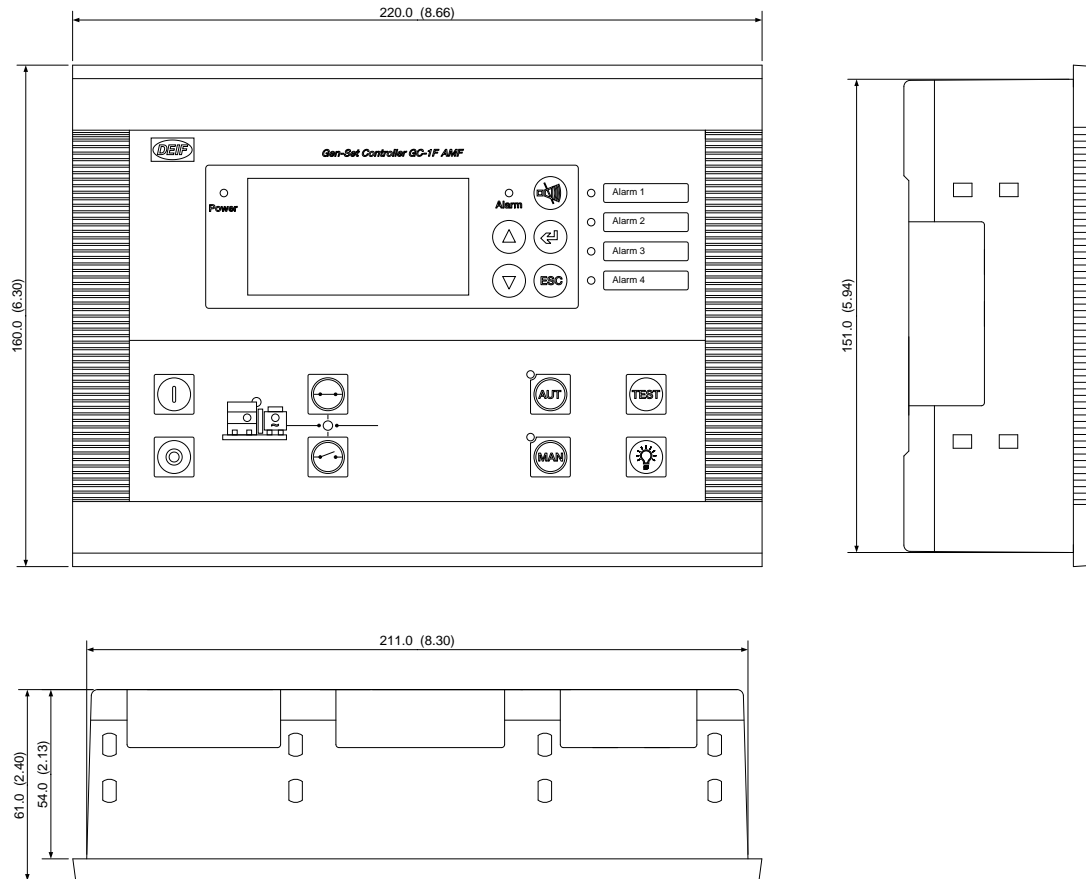

6. Ordering information

6.1 Order specifications and disclaimer

6.1.1 Order specifications

Variants

Mandatory information			Additional options to the standard variant				
Item no.	Type	Variant no.	Option	Option	Option	Option	Option

Example:

Mandatory information			Additional options to the standard variant				
Item no.	Type	Variant no.	Option	Option	Option	Option	Option
2912530020	GC-1F/2	01	M19	L	B3		

Accessories

Mandatory information		
Item no.	Type	Accessory

Example:

Mandatory information		
Item no.	Type	Accessory
1129150061	Accessory for GC-1F/2	Gasket IP65

6.1.2 Disclaimer

DEIF A/S reserves the right to change any of the contents of this document without prior notice.